



Designation: C1712 – 20

Standard Test Method for Rapid Assessment of Static Segregation Resistance of Self-Consolidating Concrete Using Penetration Test¹

This standard is issued under the fixed designation C1712; the number immediately following the designation indicates the year of original adoption or, in the case of revision, the year of last revision. A number in parentheses indicates the year of last reapproval. A superscript epsilon (ϵ) indicates an editorial change since the last revision or reapproval.

1. Scope*

1.1 This test method covers the rapid assessment of static segregation resistance of normal-weight self-consolidating concrete (SCC). The test does not measure static segregation resistance directly, but provides an assessment of whether static segregation is likely to occur.

1.2 The test apparatus and protocol were developed based on tests with SCC mixtures containing saturated surface dry (SSD) coarse aggregates ranging in relative density from 2.67 to 2.79 and in nominal maximum size from 9.5 mm to 25 mm. For SCC mixtures outside these ranges, testing is recommended to establish a correlation between penetration depth and static segregation measured in accordance with Test Method C1610/C1610M. This test method shall not be used to assess the static segregation resistance of self-consolidating concrete containing lightweight aggregates or heavyweight aggregates without prior testing to establish a correlation.

1.3 The values stated in SI units are to be regarded as standard. No other units of measurement are included in this standard.

1.4 The text of this standard references notes and footnotes that provide explanatory material. These notes and footnotes shall not be considered as requirements of the standard.

1.5 *This standard does not purport to address all of the safety concerns, if any, associated with its use. It is the responsibility of the user of this standard to establish appropriate safety, health, and environmental practices and determine the applicability of regulatory limitations prior to use. (Warning—Fresh hydraulic cementitious mixtures are caustic and may cause chemical burns to skin and tissue upon prolonged exposure.²)*

¹ This test method is under the jurisdiction of ASTM Committee C09 on Concrete and Concrete Aggregates and is the direct responsibility of Subcommittee C09.47 on Self-Consolidating Concrete.

Current edition approved April 1, 2020. Published May 2020. Originally approved in 2009. Last previous edition approved in 2017 as C1712 – 17. DOI: 10.1520/C1712-20.

² Section on Safety Precautions, Manual of Aggregate and Concrete Testing, *Annual Book of ASTM Standards*, Vol. 04.02.

1.6 *This international standard was developed in accordance with internationally recognized principles on standardization established in the Decision on Principles for the Development of International Standards, Guides and Recommendations issued by the World Trade Organization Technical Barriers to Trade (TBT) Committee.*

2. Referenced Documents

2.1 ASTM Standards:³

C125 Terminology Relating to Concrete and Concrete Aggregates

C143/C143M Test Method for Slump of Hydraulic-Cement Concrete

C172/C172M Practice for Sampling Freshly Mixed Concrete

C173/C173M Test Method for Air Content of Freshly Mixed Concrete by the Volumetric Method

C192/C192M Practice for Making and Curing Concrete Test Specimens in the Laboratory

C1610/C1610M Test Method for Static Segregation of Self-Consolidating Concrete Using Column Technique

C1611/C1611M Test Method for Slump Flow of Self-Consolidating Concrete

C1758/C1758M Practice for Fabricating Test Specimens with Self-Consolidating Concrete

3. Terminology

3.1 Definitions:

3.1.1 For definitions of terms used in this test method, refer to Terminology C125.

3.2 Definitions of Terms Specific to This Standard:

3.2.1 *static segregation resistance, n*—resistance of a concrete mixture to segregation of the mortar component from the coarse aggregate while the concrete is at rest and before initial setting.

³ For referenced ASTM standards, visit the ASTM website, www.astm.org, or contact ASTM Customer Service at service@astm.org. For *Annual Book of ASTM Standards* volume information, refer to the standard's Document Summary page on the ASTM website.

*A Summary of Changes section appears at the end of this standard

4. Summary of Test Method

4.1 This test method uses a penetration apparatus (shown in Figs. 1 and 2) and an inverted slump mold (Fig. 3). A sample of freshly mixed self-consolidating concrete is placed in an inverted slump mold without tamping or vibration. The hollow cylinder attached to a metal rod is aligned in the center of the inverted slump mold as shown in Fig. 3. The hollow cylinder is then lowered onto the surface of the concrete and released to freely penetrate into the fresh concrete. The penetration depth (*Pd*) is determined and used to assess the static segregation resistance of the self-consolidating concrete mixture (1-5).⁴

5. Significance and Use

5.1 This test method is for the rapid assessment of the static segregation resistance of self-consolidating concrete.

5.2 The method is useful for rapid assessment of the static segregation resistance of self-consolidating concrete during mixture development in the laboratory as well as prior to placement of the mixture in the field. Test Method C1610/C1610M for static segregation of SCC is not sufficiently rapid, and the non-mandatory Visual Stability Index as determined through the procedure described in Appendix X1 of Test Method C1611/C1611M is highly subjective and qualitative.

5.3 Appendix X1 provides non-mandatory criteria that may be used to indicate the degree of static segregation resistance of self-consolidating concrete mixtures.

6. Apparatus

6.1 *Mold*—The slump mold is used in this test method and shall conform to Test Method C143/C143M.

6.2 *Penetration Apparatus*—The penetration apparatus, shown in Fig. 1, consists of a support frame, a metal sleeve, a set screw, a penetration head and a reading scale. The penetration head, consisting of a non-corrosive hollow cylinder and a metal rod, has a mass of 45 ± 1 g. The rod is bolted vertically into the center of the top of the hollow cylinder and acts as a unit with the cylinder. The inner diameter, wall thickness, and height of the hollow cylinder are 75 ± 1 mm, 1.5 ± 0.1 mm, and 50 ± 1 mm, respectively. Holes are symmetrically drilled on the top surface of the hollow cylinder to allow air to escape during the penetration test. At least two holes with a minimum diameter of 6 mm must be provided (see Note 1). The reading scale shall be 55 mm long and marked in 1 mm increments. The scale is mounted on the support frame and adjacent to the metal rod, as shown in Figs. 1 and 2. With both the support frame and the hollow cylinder resting on a flat surface, the top of the metal rod shall be 5 mm below the top of the reading scale (see Note 2). The diameter of the metal rod shall be 4.5 ± 0.5 mm. The inner diameter of the metal sleeve shall be 0.7

⁴ The boldface numbers in parentheses refer to a list of references at the end of this standard.

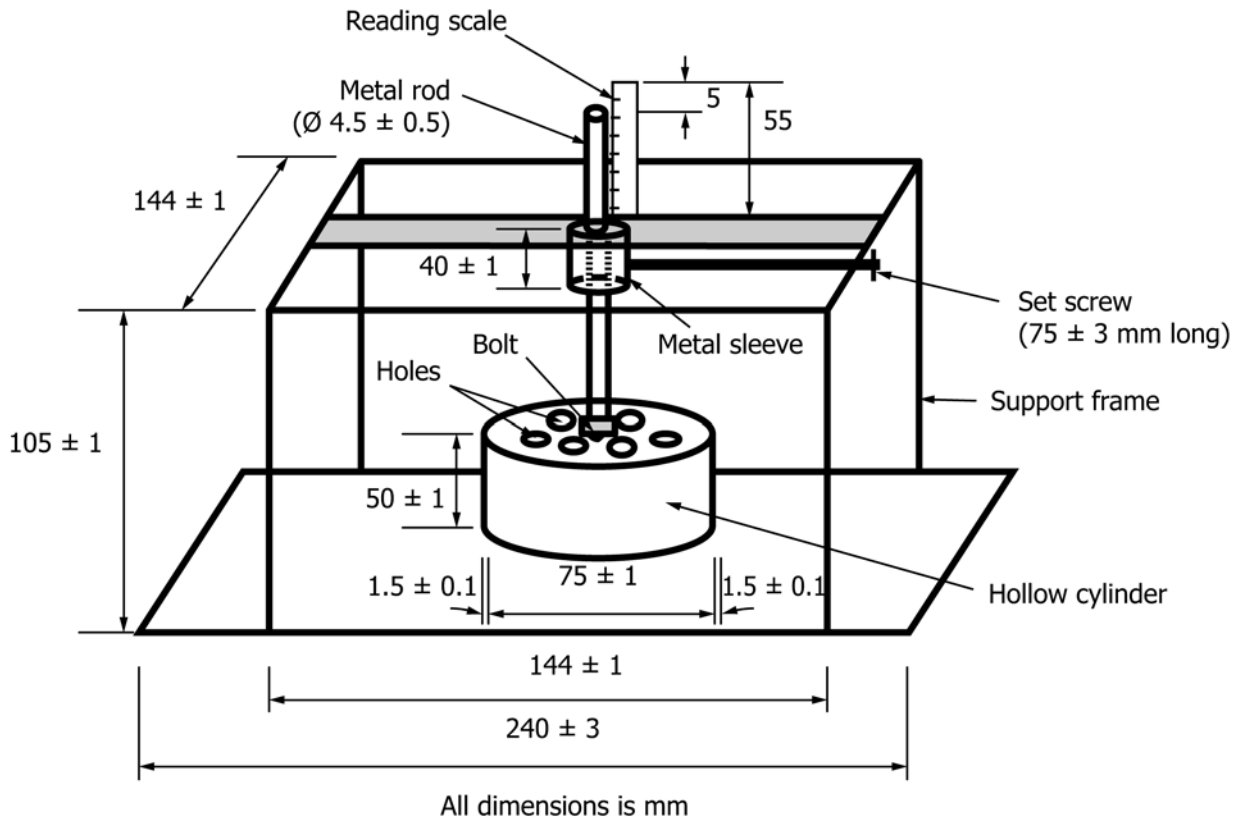

FIG. 1 Dimension of Penetration Apparatus